

STEAM SAMPLING 101

Basics and What Really Matters

Steam sampling is sometimes viewed as a necessary evil in a process plant. However, the absence of steam due to a boiler shutdown makes for a bad day at a refinery, petrochemical or specialty chemical plant. This paper discusses some of the latest steam sampling guidance from EPRI (Electric Power Research Institute) and IAPWS (International Association for the Properties of Water and Steam) and how to practically implement steam sampling guidelines in a process environment. One size doesn't fit all and a number of variables must be considered to design a practical, reliable system. An overview of analytical options associated with steam sampling is included along with discussion of possible solutions to real world limitations such as lack of "good" cooling water, inadequate space or budget for a system.

INTRODUCTION

This paper touches a lot of related topics (chemical treatment, on line analysis, boiler operation, feedwater treatment, etc.) in a cursory manner. This paper also provides an overview of these items for those unfamiliar with them. References are provided for those who want to dig deeper into these topics.

Steam sampling is critical in a process plant because steam is a required utility for most chemical, petrochemical and refining processes. Without it, molecules don't get cracked, reactors don't get heated and hopes for high yielding chemical processes don't materialize. Steam impurity may cause operational issues with turbines and other process equipment, corrosion of process components and/or scaling of metal surfaces. To mitigate these risks, analysis of process steam and condensate is an important aspect of any chemical processing or refining operation. Impurities in these systems such as silica, sodium or deviations from target pH values can wreak havoc on a plant's operations. On-line analysis of sodium and cation conductivity is commonly performed to monitor the condition of process steam.

SOURCES OF STEAM IMPURITIES

The International Association for the Properties of Water and Steam (IAPWS) describes steam monitoring this way: "Steam is monitored to ensure adequate purity, free from excessive carryover of boiler constituents (drum boilers only), free from constituents derived from contaminated spray water, and free from unacceptable concentrations of silica that could form deposits in turbines." (1). But where do all these impurities come from?

For most process plants, steam is produced either in a once through steam generator (OTSG) or in a drum boiler. OTSGs are a special case, so this paper will focus on drum boilers for simplicity. A drum boiler is fed by boiler feed-water which is a combination of condensate (condensed steam returned to the system) and make-up water. Make-up water typically is generated by robust pre-treatment of "raw" water by using a combination of appropriate mechanical (clarifiers, RO membranes, etc.) and chemical treatments/reactions (demineralizers) to produce highly pure water for use in industrial processes.

For this simplified system, impurities come from incomplete pre-treatment of raw water, from condensate returns or from chemical treatment additives. Chemicals for pH control and buffering are intentionally introduced to boilers in various forms of phosphate treatment (tri-sodium phosphate is quite common) and caustic treatment (sodium hydroxide based typically) (2). Process steam may be exposed to various chemical impurities during its use in the plant. Condensate treatment is beyond the scope of this paper, but suffice it to say that online monitoring of return condensate TOC (Total Organic Carbon) or other suspected contaminants (silica, sodium, chloride, etc.) is recommended to prevent injecting "bad" returned condensate to the boiler feedwater and, subsequently, the steam system (3).

In terms of the drum boiler itself, the aforementioned chemical treatments result in sodium in the boiler water. Target levels of sodium are maintained by performing periodic blowdown of excessive boiler impurities and replenishing the boiler drum with "cleaner" feedwater to maintain a balance. That being said, even when sodium levels in a boiler are within spec, excessive levels of sodium (or other steam impurities) can "carryover" into the steam by mechanical or vaporous mechanisms.

Mechanical carryover is the entrainment of water droplets in steam exiting the boiler. Its severity depends on the condition of the water/steam separators, drum level control, and operating conditions. Vaporous carryover occurs due to the inherent volatility of the compounds present in the boiler water. Some compounds, e.g., ammonia and amines, are deliberately added to the water/steam circuit as conditioning chemicals, because they are volatile and can protect various parts of the boiler water/steam circuit during operation and off-load conditions. Except for these plant conditioning chemicals and a few substances like silica, for boiler systems less than about 2300 psi (higher than most plant process boiler pressures, but lower than many high pressure utility boiler pressures), vaporous carryover is negligible (1).

For most industrial boilers, mechanical carryover poses a more present danger. Reference 1 describes periodic monitoring of carryover essential for chemistry control and the separation of mechanical carryover for guarantee purposes. Total carryover is determined by measuring the mass concentration of sodium in the boiler water and in steam. The mechanical carryover represents the fraction of water entrained from the boiler drum into the steam and is determined by correcting the total carryover for any contribution of vaporous carryover. Reference 1 details procedures to determine the source of carryover (vaporous or mechanical) for higher pressure systems.

STEAM IMPURITIES: HOW MUCH IS TOO MUCH?

Bad steam can cause loss of availability of process components, so avoiding that situation is important. But what differentiates "good" steam from bad? An established principle in ASME guidelines (4) shows that fewer impurities are allowable as boiler pressures increase. As process pressure and temperature increases, ppm level impurities must be reduced to ppb level to avoid failures. While most process plants have a variety of steam types (low pressure, intermediate pressure and high pressure), this paper focuses on high pressure steam and its requirements since they are the most limiting. Acceptable impurity levels for your particular process, if not already established or if they haven't been reviewed recently, should be determined or confirmed in cooperation with a professional water chemistry consultant or experienced (and preferably unbiased) water treatment professional.

OVERVIEW OF STEAM SAMPLING

When it comes to sampling the impurities recommended for analysis (3), a quick survey of the technologies used for ultrapure water (condensed steam) analysis shows that most of the instruments utilized rely on measurement curves centered at 77°F (25°C). Further, most of the technologies use techniques that are not well suited for application at process pressures and temperatures. As a result, steam samples must be condensed into a liquid, with pressure and temperature and flow controlled, before introduction to the analytics commonly used for steam analysis.

In order to achieve accurate analysis, EPRI, ASTM and ASME recommend cooling water samples to 77°F (25°C) to ensure consistent, accurate analysis (5, 6 and 7). Unfortunately, cooling water temperatures in process plants commonly exceed 100°F (38°C). While this is acceptable to provide rough cooling, it is insufficient temperature control for samples using online pH, cation conductivity or similar analyzers.

A well-designed sample conditioning system for an individual sample consists of the following components (Reference 5):

- Inlet isolation valve
- Blowdown valve (High and/or Low Pressure)
- Primary Sample Cooler and associated inlet and outlet valves
- Primary Cooler relief valve
- Pressure Reducing Valve
- Thermal Shutoff Valve
- Secondary Cooler
- Pressure and Temperature Gauge
- Total Line and Individual Analyzer Flow Indicators
- Back Pressure Regulating Relief Valve

These components are a combination of pressure, temperature, and flow conditioning to ensure a representative sample that is safe for the operator. A well-designed system needs to be laid out in the most ergonomic fashion possible to ensure that all equipment is easily accessible without disturbing adjacent equipment. To facilitate a safe and operable working environment, sufficient lighting must be provided at the location of the sample conditioning system.

A typical P&ID (process and instrumentation diagram) of these components is shown below in Figure 1 (5). While this system may appear complex, all required components will fit on a stainless-steel back-plate for easy installation (See Figure 2).

SYSTEM DESIGN CONSIDERATIONS

To configure a system, there are a few questions a potential user must consider in order to design a successful system. These choices are as follows:

1. Is my sample pressure > 500 psig or < 500 psig? If greater, a rod-in-tube device such as a variable pressure reducing element (VREL) is required to avoid dissociation of water and to ensure reliability. This device “spreads” the pressure drop across a large surface area vs. taking the drop across a small surface like a needle valve. A needle valve is acceptable for pressure drop for sample pressures <500 psig (6).
2. Is this sample point for grab sample only or am I feeding online analyzers? For high-pressure steam systems, online steam analysis is common. However, in cases where no online analyzer is utilized (low pressure systems), no back pressure regulator is required (6).
3. Should an automatic thermal protection safety device be used in the system? Thermal shutoff valves (TSV) are often applied for steam systems where one of the following applies: 1) Operators interact frequently with this system; 2) Expensive analyzers are part of the system; or 3) The steam sampling system is located in a high traffic area. A TSV automatically shuts off sample flow when samples exceed safe temperatures (5).

4. What cooling sources do I have available at the proposed installation site?

The answer to this final question is a bit more involved and includes corollary questions such as:

- 1) What size sample cooler is required?
- 2) Will it be necessary to utilize a primary and a secondary sample cooler as Reference 5, 6 and 7 recommend?
- 3) Where must the primary cooler be located to have access to acceptable cooling water?
- 4) What cooling source is available to achieve sample cooling to approximately 77F (25C)?

To answer, understanding of cooling water impacts and heat loads is in order. Figure 3 shows a primary sample cooling heat load calculations for a typical 1500 pound steam sample and cooling water temperature of 95F. Calculations show the primary heat load is 33 times the secondary (polishing) cooler heat load (Figure 4). As a result, refrigeration systems (chillers) are typically not utilized for primary cooler due to size and cost. However, secondary sample coolers in utility areas (where multiple samples are commonly located) are commonly cooled by chilled water from a temperature control unit (TCU or chiller system) which consistently provides a constant 77F/25C +_1 final sample temperature.

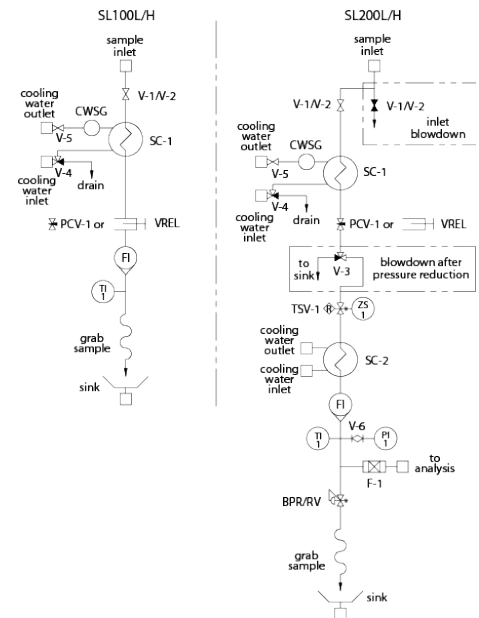

FIGURE 1. TYPICAL STEAM SAMPLING SYSTEM P&ID



FIGURE 2. TYPICAL PROCESS STEAM SAMPLING SYSTEM

Sample Name	<input type="checkbox"/> ASME Cooler	T in F	Pressure PSIA	Flow cc/min	Flow GPM	T in F	T out F	Heat Load BTU/hr	Pressure Drop PSI	T cooler F	T prv F
Sat Steam	<input type="checkbox"/> TLR4225	510	430	1000	7	95	137.5	148524	14.5	110.5	111.5

FIGURE 3. PRIMARY SAMPLE COOLING HEAT LOAD FOR A 1500 PSI STEAM SAMPLE

Sample Name	Cooler	T in F	Pressure PSIA	Flow cc/min	Flow GPM	T in F	T out F	Load BTU/hr	Drop PSI	T cooler F
Sat Steam	TLR4225	111.5	60	1000	3	76	79.0	4495	17.9	77.2

FIGURE 4. SECONDARY SAMPLE COOLING HEAT LOAD FOR A 1500 PSI STEAM SAMPLE

Primary sample cooling is typically accomplished with plant cooling water at the nearest available location (remote from the analyzers if necessary) to “rough cool” the sample. This rough cooling process oftentimes leaves excessively high sample temperatures (over 100F) for the analyzers. Note Tprv, the temperature of the sample after pressure reduction, of 111.5 in Figure 3 above. Thus, secondary cooling is required.

If secondary sample coolers are fed by plant cooling water rather than chilled water at 76F (like that shown in Figure 4), calculations confirm an approach temperature of less than 2F to the cooling water temperature (compared to the 15F+ approach temperature from the primary cooler shown in Figure 3). This moves the final sample temperature closer to the recommended target temperature of 25C.

However, if the primary sample cooling water is of poor quality (high sediment, calcium carbonate scaling, etc.), extremely high sample temperatures may result and prohibit reliable long-term performance or accuracy. In cases where the plant recognizes poor quality cooling water as an ongoing problem, substitution of high temperature, but clean condensate as primary cooling water may improve the performance.

For example, if a process unit has clean, 120F condensate available, primary sample coolers may last longer and perform more consistently than if they use 95F plant cooling water with high hardness or chlorides (city water). In these cases, it is possible to use vortex coolers fed by plant air to provide a few thousand BTU of cooling to drop the sample temperature significantly.

An example of a vortex cooler based secondary cooler system is shown in Figure 5.

SAMPLE COOLING DESIGN CONSIDERATIONS

The following are a few safety considerations related to operation and design of steam sampling systems. Each should be considered when designing or utilizing a system:

- 1) A means of sample relief must be provided on each sample line. Combination backpressure regulating/relief valves or variable pressure regulating valves with separate relief valves may be used. A high Cv combination back pressure/relief valve (BPRV) ensures constant sample flow and non-plugging pressure relief function and may eliminate the need for a dedicated pressure relief line.
- 2) Material selection – for cooling water sources derived from city water or otherwise containing high levels of chlorides, Inconel (Alloy 625 or similar) sample tubes are recommended in place of stainless steel to avoid stress corrosion cracking.



FIGURE 5. VORTEX BASED SECONDARY COOLING SYSTEM

3) Ensure cooling water lines supplying the primary sample cooler are sized appropriately. Common field errors include use of sample tubing instead of piping for the cooling water service. Sample tubing has a smaller internal area than piping with the same outer diameter (OD). Samples should be routed with tubing, cooling water with piping typically. Insufficient cooling water flow will result in rapid cooler failure.

4) Setup sample coolers with isolation valves so they can be drained and to provide pressure relief on the shell side of the cooler in the event of a loss of cooling water incident – see diagram including inlet ball valve (which should be fully open during normal operation) and relief valve in Figure 6.

5) In addition, note the cooling water flow globe valve is located downstream of the cooler to maintain a backpressure and minimize cavitation and boiling of cooling water in the cooler.

6) The isokinetic sample flow required for the sample line usually exceeds the flow required by pure water analytics. For this reason, analyzers should be operated on a branch line and the surplus flow sent to drain or a sample recovery system.

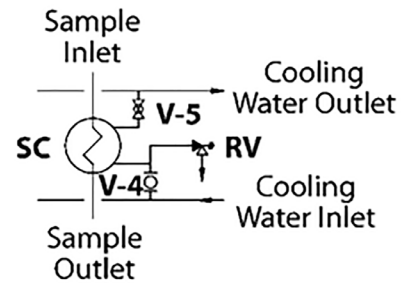

FIGURE 6. SAMPLE COOLING WATER RELIEF VALVE ARRANGEMENT

OVERVIEW OF STEAM ANALYSIS

Table I shows publicly available guidance provided by IAPWS (www.iapws.org) recommending the parameters necessary to monitor to ensure adequate steam purity (3):

Steam	Saturated	Conductivity after cation exchange Sodium	Iso-kinetic sampling is necessary.
	Superheated/ Reheated	Conductivity after cation exchange Sodium Silica Degassed CACE	

TABLE 1. IAPWS RECOMMENDED PARAMTERS FOR STEAM MONITORING

Recent Electric Power Research Institute (EPRI) recommendations for combined cycle steam measurements (as interpreted by a large utility and documented in Reference 9) include measurement of CACE (conductivity after cation exchange), degassed cation conductivity and sodium for low, intermediate and high pressure steam. This is generally consistent with IAPWS guidance above, noting that this particular plant was not concerned about silica in the steam due to operating history.

Continuous monitoring of superheated steam is required in industrial boiler systems where water less pure than saturated steam is used for direct spray de-superheating or attemperation (Reference 8). Typically, attemperation water used to cool superheated steam is the primary source of contamination. Attemperating water becomes part of the steam and may be contaminated by the feed of non-volatile treatment chemicals and return condensate corrosion products. Particularly costly are cases where steam is used directly in a process and catalyst fouling, fiber staining or product contamination can occur (8). When steam is used for indirect heating, corrosion and equipment failure tend to be the most common consequences, though high pressure steam when applied in close proximity to operators or maintenance personnel should be considered for close monitoring for safety reasons regardless of the process.

The bottom line is that steam systems must be monitored for expected contaminants and the level of vigilance must increase as the consequences of failure increase. These consequences include loss of life for high pressure and temperature systems and lost production/revenue for any system that could suffer greatly from contamination, regardless of pressure.

GENERAL DESIGN GUIDELINES

When considering options for installation of sample panels and systems, the following must be considered:

- 1) If possible, indoors or inside a temperature controlled shelter is best
- 2) Outdoor locations are acceptable if some common sense precautions are taken such as not locating analyzer displays in direct sunlight, providing proper freeze protection, providing adequate cooling for temperature sensitive electronic or sensor components, etc.
- 3) Closer to the sample source is better to minimize transport challenges, as discussed herein, and to minimize sample transit times
- 4) There must be sufficient space to access the analytics and perform maintenance.

Many engineers and designers focus on the sampling system while ignoring important design aspects such as the type of sample extraction, the size, length and diameter of the sample line. Considering the transit time of steam samples both in vapor phase and ultimately as condensed liquid is critical to ensure correct sample line velocities, maximum accuracy and performance can be obtained by the on-line analytical instrumentation.

Note that many plants utilize conductivity based steam monitoring systems to minimize space and cost. However, conductivity doesn't identify the species of contaminant and is typically slower to respond than a direct measurement of a contaminant like sodium, for example.

STEAM SAMPLING DYNAMICS

A steam sampling system design differs from a gas phase sampling system and from a single phase liquid sampling system. Steam changes state as its temperature and pressure change and these transitions must be accounted for to avoid inconsistent, non-representative results.

Figure 7 shows transition of steam from source to condensation through various states. The pressure drop and line size required to properly manage these states can be calculated by sample cooler vendors or engineering firms.

SAMPLE PROBES

Sample probes are designed to collect samples from the pipe while ensuring that the samples taken are representative of the process. However, sample extraction requirements differ when sampling saturated steam versus water (single phase liquid) or superheated steam (free from water droplets at the point of extraction).

A common point of confusion for steam and water sampling relates to the question of isokinetic sampling. Is it required?

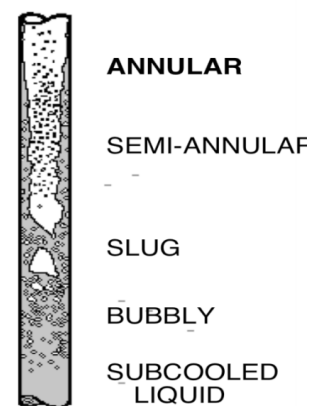

FIGURE 7. TRANSITION OF STEAM TO FULLY CONDENSED STATE

According to IAPWS guidance (1), isokinetic sampling is required for saturated steam sampling only. This is due to the nature of the sample itself, containing a mixture of droplets and vapor. In order to capture a representative sample of saturated steam, the proportion of vapor/droplets captured must match that of the sample itself.

Superheated steam, in contrast, is free from water droplets at the point of extraction. So, isokinetic sampling probes are not required for superheated steam or for single phase liquid samples. ASTM D1066 (9) and ASTM PTC 19.11 (5) gives extensive guidance on isokinetic nozzle design and application.

Users should note that isokinetic sample nozzles alone do not magically guarantee isokinetic sampling. If the sample flow rate isn't varied to match changes in steam velocity within the sample line (in the case of variable steam flows), the sample isn't truly isokinetic. Also, if operators are modifying the sample flow rate to the panel away from isokinetic conditions, the sample flow isn't truly isokinetic either.

It is the author's experience in the utility industry that isokinetic nozzles may or may not be present in steam sampling. Further, the chances that sample line flows and nozzle flows are regularly checked vs. steam flow to ensure isokinetic conditions post-install are zero. Reference 5 indicates that when proper sampling nozzles are not available, samples collected can still be utilized to detect trends and identify factors that affect carryover. However, proper sample nozzles are required for accurate data and representative sampling.

SAMPLE LINE SIZING

Recommended sample tube sizes for steam at various pressures can be found in Table 4-4.3-1 of Reference 5. A review of this table shows that the lower the steam pressure, the larger the sample line required to avoid "choking" and loss of representative sample flow.

For higher pressure steams, this is still possible but less likely since the mass in the steam at high pressure is such that it can be condensed quickly with minimal pressure loss. Lower pressure steam contains less mass per unit volume so they are more difficult to transport and condense without significant pressure drop issues. Typical sample flows required to feed on-line analyzers and maintain recommended condensed liquid velocities of approximately 6 ft/sec (6) is easier at higher pressure (7).

Maintaining the sample flow rate at as constant as possible ensures that the point of full condensation of steam within the sample line, and thus the resulting transit time of condensed liquid, remains constant. Varying steam sample flow rates frequently will move the point of full condensation within the sample line (or cooler in some cases) resulting in potential variability of the sample itself and variability in the total transit time.

To illustrate, consider these sample calculations for a 600 psig saturated steam sample in a 1/2" 316SS tube. If the same sample is routed through 1/2" 316SS pipe (larger ID), the transit time increases from 36 seconds to 331 seconds with the 1/2" pipe due to changes in the physical properties of the sample. The sample remains in a steam phase throughout the transport in the tube but in the pipe the steam is fully condensed at 203 ft and travels as condensed water the last 97 ft (Figure 8).

CONCLUSIONS

Steam sampling, like many tasks process engineers and plant analyzer technicians are faced with, is a multi-faceted undertaking. The author hopes this quick overview of some of the factors of sampling that are unique to steam is helpful for designing, operating, maintaining or troubleshooting these systems.

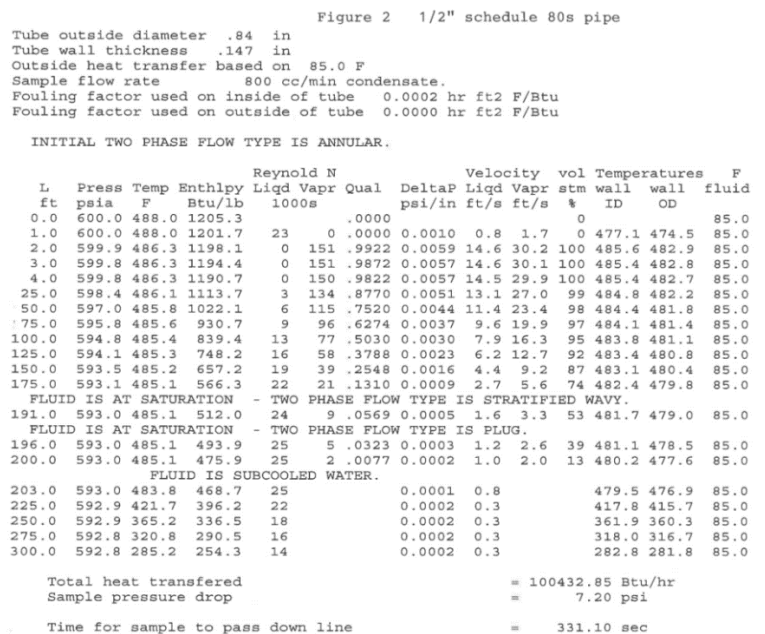

FIGURE 8. 600 PSIG SATURATED STEAM SAMPLE TRANSPORT CALCULATION

REFERENCES

- 1) Technical Guidance Document: Procedures for the Measurement of Carryover of Boiler Water into Steam; The International Association for the Properties of Water and Steam (IAPWS) TGD1-08; September 2008, pages 1 – 11.
- 2) The Nalco Water Handbook, Second Edition, 1988, page 39.17.
- 3) Technical Guidance Document: Instrumentation for monitoring and control of cycle chemistry for the steam-water circuits of fossil-fired and combined-cycle power plants; The International Association for the Properties of Water and Steam (IAPWS) TGD2-09(2015); July 2015, pages 22-23.
- 4) Consensus on Operating Practices for the Control of Feedwater and Boiler Water Chemistry in Modern Industrial Boilers, CRTD-Vol. 34, pages 22-23.
- 5) Steam and Water Sampling, Conditioning, and Analysis in the Power Cycle. American Society of Mechanical Engineers (ASME), West Conshohocken, PA 2008, PTC 19.11-2008, pages 8-10, 16-17, 21.
- 6) Standard Practice for Flow Control and Temperature Control for On-Line Water Sampling and Analysis. American Society of Testing and Materials (ASTM), West Conshohocken, PA 2013, D5540-13, pages 1-5.
- 7) Guidance on Design, Operation and Maintenance of Steam and Water Sample Conditioning Systems, EPRI Project Manager Steve Shulder; Authored by Sentry Equipment Corp, WBS 1-1-5792-01-01, Final Report, June 2014, page 3-4.
- 8) A Practical Guide to Avoiding Steam Purity Problems in the Industrial Plant; ASME Research Report, CRTD-Vol. 35, pages 8, 14.
- 9) Standard Practice for Sampling Steam. American Society of Testing and Materials (ASTM), West Conshohocken, PA 2011, D1066-11, pages 1-5.

sentry-equip.com

966 Blue Ribbon Circle North, Oconomowoc, WI 53066 U.S.A. | +1-262-567-7256 | sales@sentry-equip.com

© 2017 Sentry Equipment Corp

S-SW--WHT-00516-1 08-17

